

# 2019

## FALL

MILLING NEW PRODUCTS

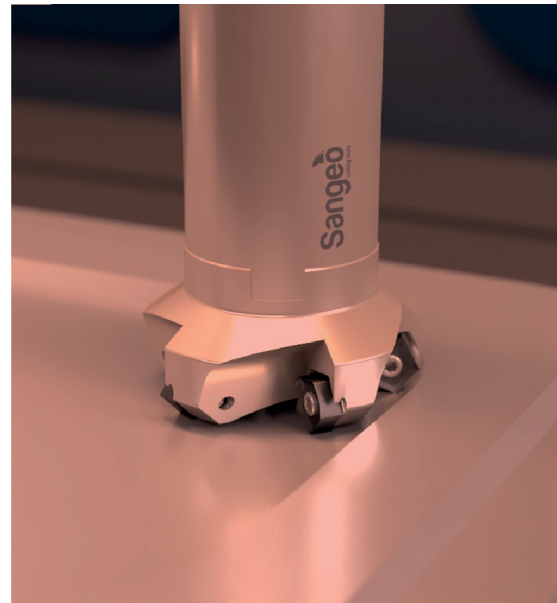
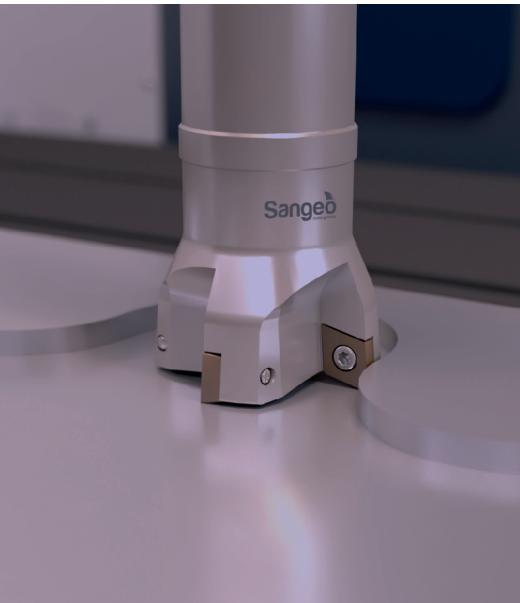

The logo for Sangeo cutting tools, featuring the brand name in a bold, sans-serif font with a small icon above the 'o', and the words 'cutting tools' in a smaller font below it.

Sangeo  
cutting tools

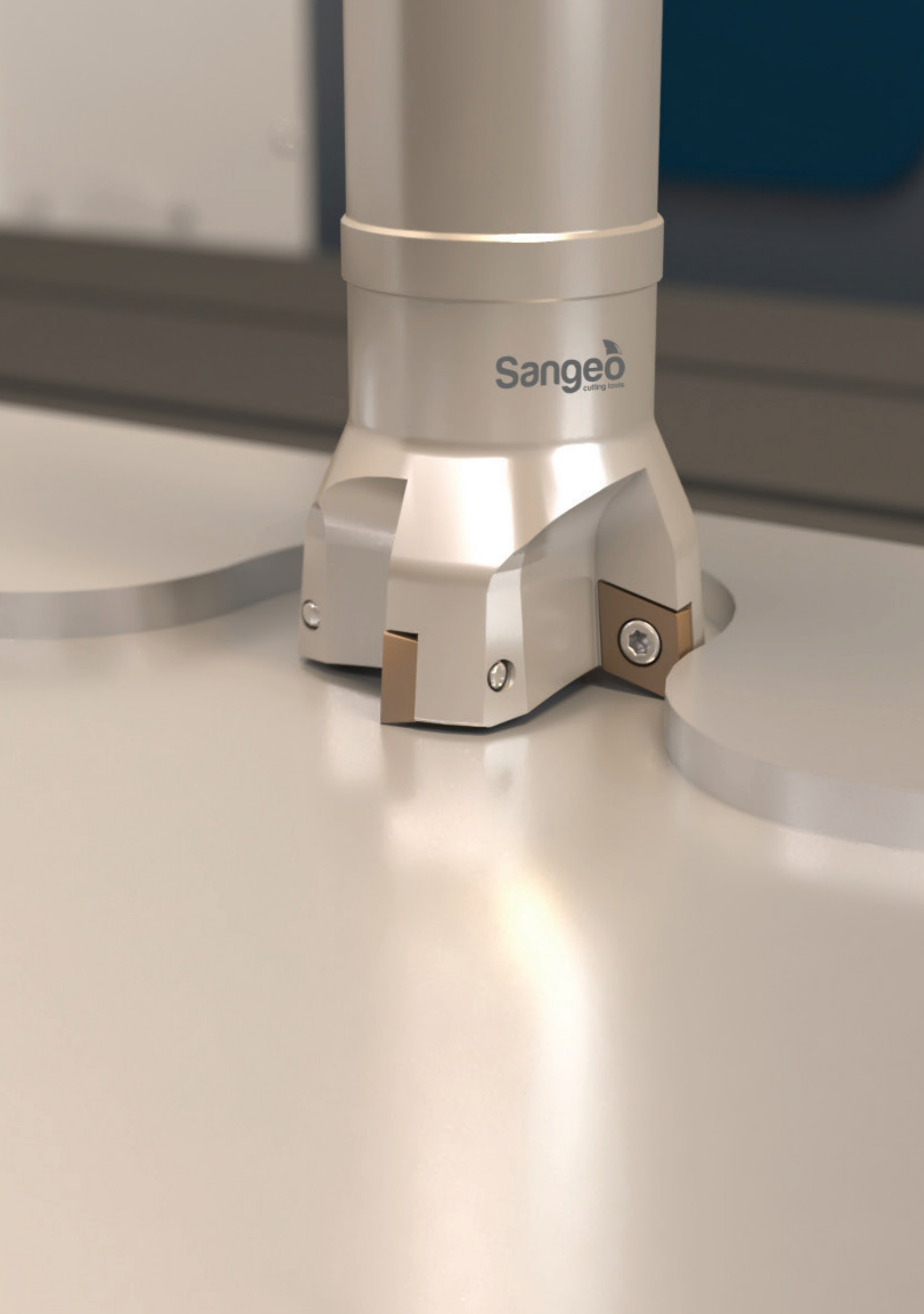

# Sangeo cutting tools

NEGATIVE  
with hole

# LOGX

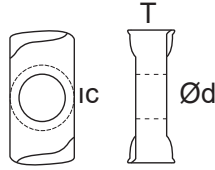

LOGX 0303

IC 6,2

T 3,96

Ød 3,45



DESCRIPTION			CARBIDE										
			PS5915	PS5925	PS5960	CS8915	CS8925	PS7925	US2915				
	LOGX	030310-FH	•						•				

Vc • fn • ap 7

## MILLING

NEGATIVE 45°  
with hole

# PNMU

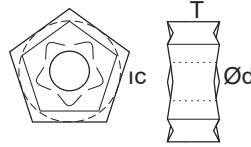

PNMU 0905

IC	14,60
T	5,56
Ød	4,7

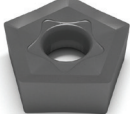

10

DESCRIPTION			CARBIDE										
			PS5915	PS5925	PS5960	CS8915	CS8925	PS7925	US2915				
	PNMU	0905XNER-MM	•						•				

Vc • fn • ap



7

POSITIVE  
with hole

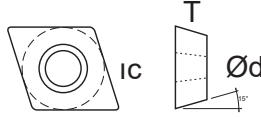
# XDHX



XD	0602	10T3
IC	6,5	10
T	2,38	3,97
Ød	2,8	4
Holder	10	10

DESCRIPTION			CARBIDE										
			PS5915	PS5925	PS5960	CS8915	CS8925	PS7925	US2915				
	XDHX	060210-SS	•						•				
	XDHX	10T310-SS	•						•				

Vc • fn • ap  7

## MILLING

### Cutting Parameters $a_p$ (mm) & $f_n$ (mm/rev)

LOGX				0303							
Material	Chip Breaker	$a_p$ (mm)	$f_n$ (mm/rev)	$a_p$ (mm)	$f_n$ (mm/rev)	$a_p$ (mm)	$f_n$ (mm/rev)	$a_p$ (mm)	$f_n$ (mm/rev)	$a_p$ (mm)	$f_n$ (mm/rev)
K											
P	FH	0,2~1,2	120~250								
M	FH	0,2~0,9	80~180								
N											



PNMU				0905							
Material	Chip Breaker	$a_p$ (mm)	$f_n$ (mm/rev)	$a_p$ (mm)	$f_n$ (mm/rev)	$a_p$ (mm)	$f_n$ (mm/rev)	$a_p$ (mm)	$f_n$ (mm/rev)	$a_p$ (mm)	$f_n$ (mm/rev)
K											
P	MM	0,8~4,0	120~250								
M	MM	0,8~4,0	100~220								
N											

XDHX				0602		10T3					
Material	Chip Breaker	$a_p$ (mm)	$f_n$ (mm/rev)	$a_p$ (mm)	$f_n$ (mm/rev)	$a_p$ (mm)	$f_n$ (mm/rev)	$a_p$ (mm)	$f_n$ (mm/rev)	$a_p$ (mm)	$f_n$ (mm/rev)
K											
P	SS	0,5~1,0	140~280	0,5~1,5	140~270						
M	SS	0,5~1,0	140~220	0,5~1,5	140~220						
N											

### MFLO

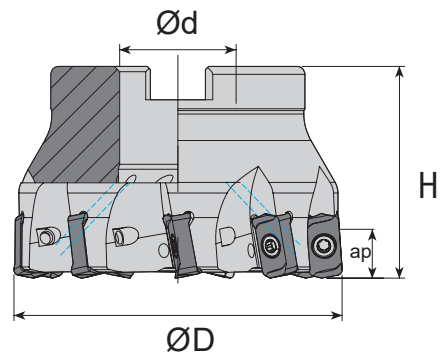
### LOGX





LO	DESCRIPTION	STOCK	DIMENSIONS					PROGRAM RADIUS	MAX. ANGLE FOR RAMPING	 ← 		
			D	H	d	Z	ap					
LO 03	MFLO	040R-03-6T-C	●	40	40	16	6	8	1,6	0,5°	ST-SC0360	ST-WRT08
		050R-03-7T-C	●	50	40	22	7	8	1,6	0,4°	ST-SC0360	ST-WRT08
		063R-03-9T-C	●	63	40	22	9	8	1,6	0,3°	ST-SC0360	ST-WRT08

### MMLO

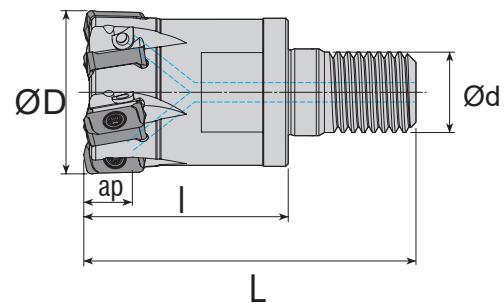
### LOGX



LO	DESCRIPTION	STOCK	DIMENSIONS					PROGRAM RADIUS	MAX. ANGLE FOR RAMPING	 ← 		
			D	L	I	d	Z					
LO 03	MMLO	16-M08-03-2T-C	●	16	52	23	M08	2	1,6	2,8°	ST-SC0360	ST-WRT08
		20-M10-03-3T-C	●	20	52	30	M10	3	1,6	1,7°	ST-SC0360	ST-WRT08
		25-M12-03-4T-C	●	25	52	35	M12	4	1,6	1,2°	ST-SC0360	ST-WRT08
		32-M16-03-5T-C	●	32	64	43	M16	5	1,6	0,8°	ST-SC0360	ST-WRT08
		35-M16-03-5T-C	●	35	64	43	M16	5	1,6	0,7°	ST-SC0360	ST-WRT08
		40-M16-03-6T-C	●	40	67	43	M16	6	1,6	0,5°	ST-SC0360	ST-WRT08
		42-M16-03-6T-C	●	42	67	43	M16	6	1,6	0,5°	ST-SC0360	ST-WRT08





### MFPN

### PNMU

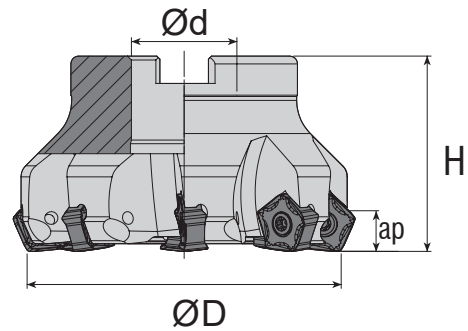

PN	DESCRIPTION	STOCK	DIMENSIONS									
			D	H	d	ap	Z					
PN	MFPN	45050R-4T-C	●	50	40	22	5	4	ST-SC0411	ST-WRT15		
		45063R-5T-C	●	63	45	22	5	5	ST-SC0411	ST-WRT15		
		45080R-6T-C	●	80	50	27	5	6	ST-SC0411	ST-WRT15		
		45100R-7T-C	●	100	50	32	5	7	ST-SC0411	ST-WRT15		

### MMXD

### XD□□

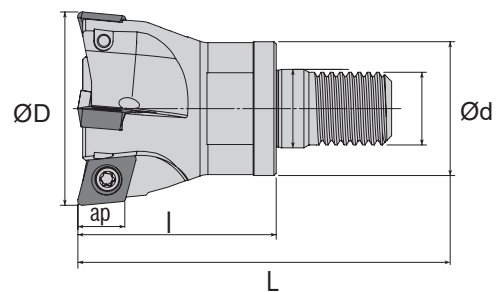

XD	DESCRIPTION	STOCK	DIMENSIONS									
			D	H	d	ap	Z					
XD 06	MMXD	16-M08-06-2T-C	●	16	52	M08	1,0	2	ST-SC0256	ST-WRT08		
		20-M10-06-3T-C	●	20	52	M10	1,0	3	ST-SC0256	ST-WRT08		
		25-M12-06-3T-C	●	25	52	M12	1,0	3	ST-SC0256	ST-WRT08		
XD 10	MMXD	35-M16-10-3T-C	●	35	64	M16	1,5	3	ST-SC3508	ST-WRT15		
		42-M16-10-4T-C	●	42	67	M16	1,5	4	ST-SC3508	ST-WRT15		

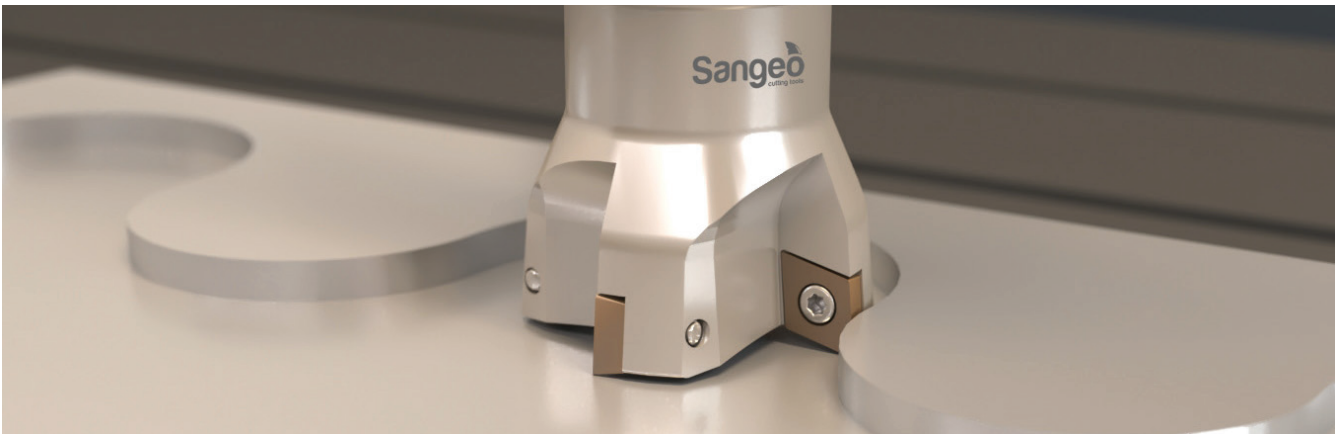
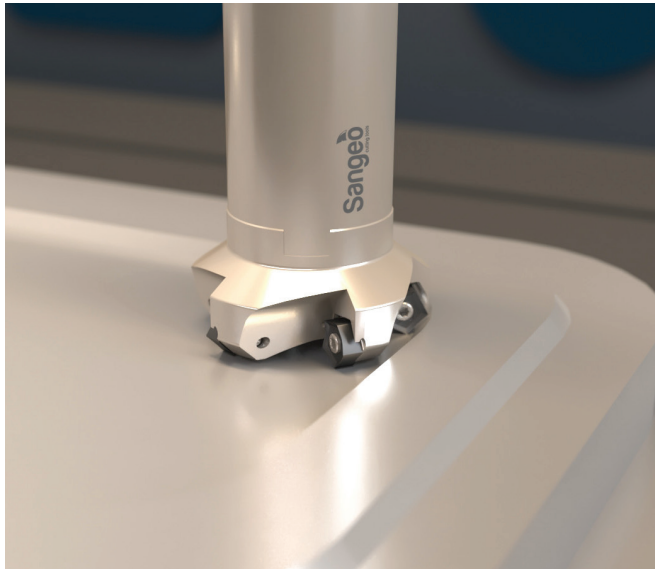
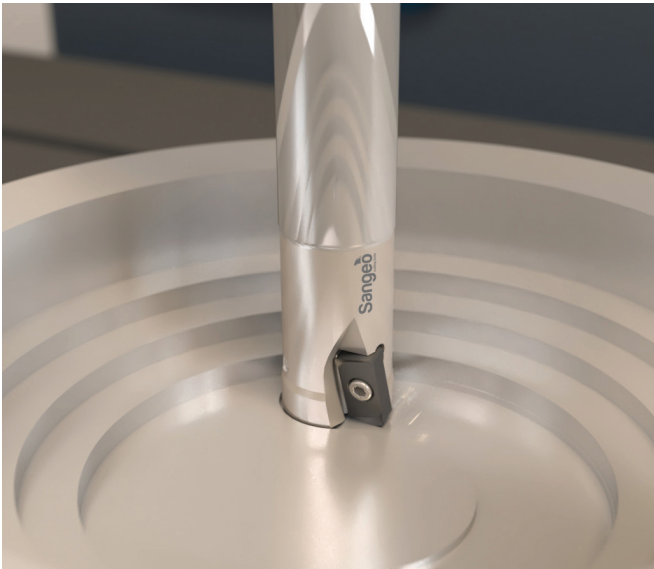



**Sangeo**  
cutting tools



HEAD OFFICE

Sangeo Metal İşleme Ürünler Dış Tic. Ltd. Şt.  
Şekerpinar mah. Nergis sok. Akpınar Plaza No:2/107 Çayırova/Kocaeli - Turkey  
TEL : +90 850 532 05 83 FAX : +90 212 924 54 56  
info@sangeo.com.tr www.sangeo.com.tr